



QuikWater Leveler[®]

Installation Instructions
& User Guide



A&A Manufacturing

Rev. 20200108

© Copyright2020 A&A Manufacturing. All rights reserved.

(Blank Page)



Prior to Installation



CAUTION

The QuikWaterLeveler must be installed by a licensed or certified plumber or a qualified pool professional adhering to all applicable local codes and ordinances.

IMPORTANT

The installer must read this manual completely before attempting installation. Consult A&A Manufacturing with any question regarding this product. This guide must be left with the pool owner or operator.

ABS to PVC transitional glue must be used between the QuikWaterLeveler body and PVC schedule 40 pipe.

NOTE:

The QuikWaterLeveler is an in-ground unit designed to control and regulate the delivery of fresh water to a pool, spa or other basin. Using the QuikWaterLeveler in a manner outside of its intended purpose may void the warranty.

Included

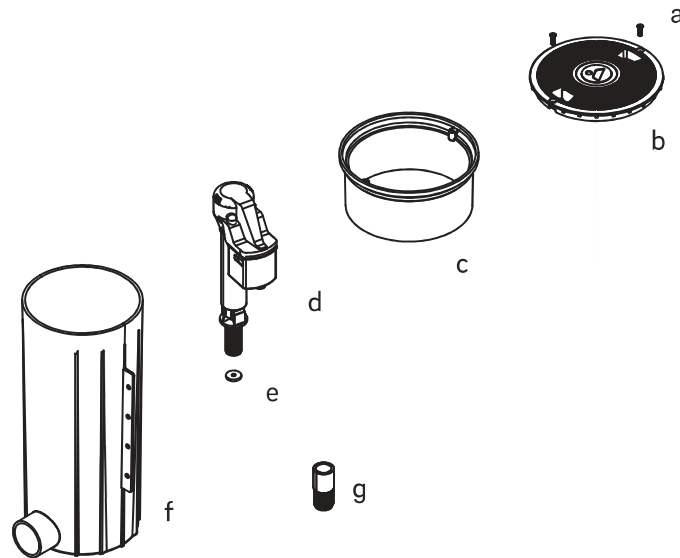

Figure 1

a. #2 Phillips SS screws (qty 2)

b. Lid

c. Deck ring

d. Float assembly

e. Restrictor seal

f. Canister

g. Pressure testing plug

Locating the QuikWaterLeveler

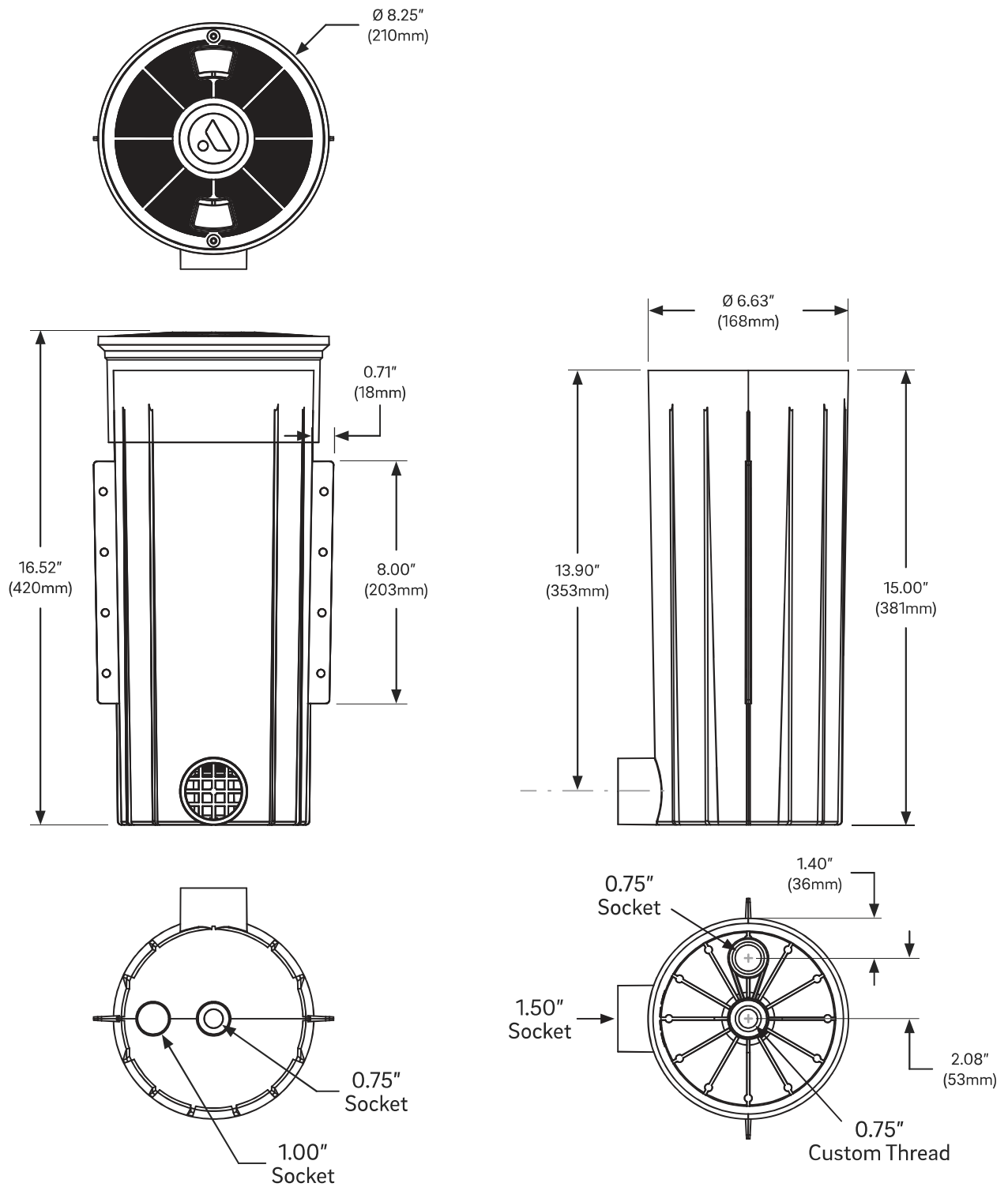

Figure 2

1. To ensure a proper height for poured concrete decks, the top of the QuikWaterLeveler canister should be set 1" **above** the top of the bond beam and as close to the form as possible. This setting will position with the 1.5" discharge line approximately 12.75" below the top of the form (Figure 3).

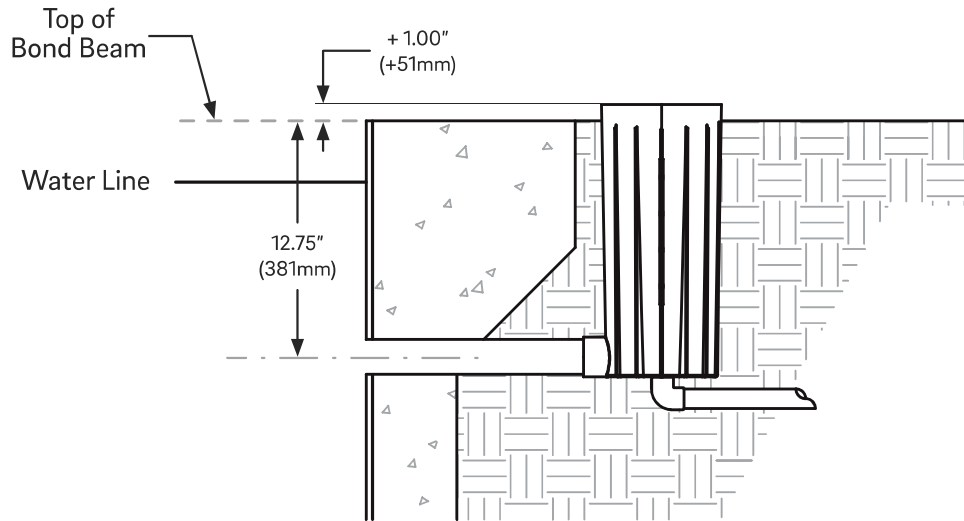

Figure 3

2. When using travertine or other thin deck material, make sure the top of the QuikWaterLeveler canister is set 1" **below** the top of the bond beam and as close to the form as possible. This will position with the 1.5" discharge line approximately 14.75" below the top of the form (Figure 4).

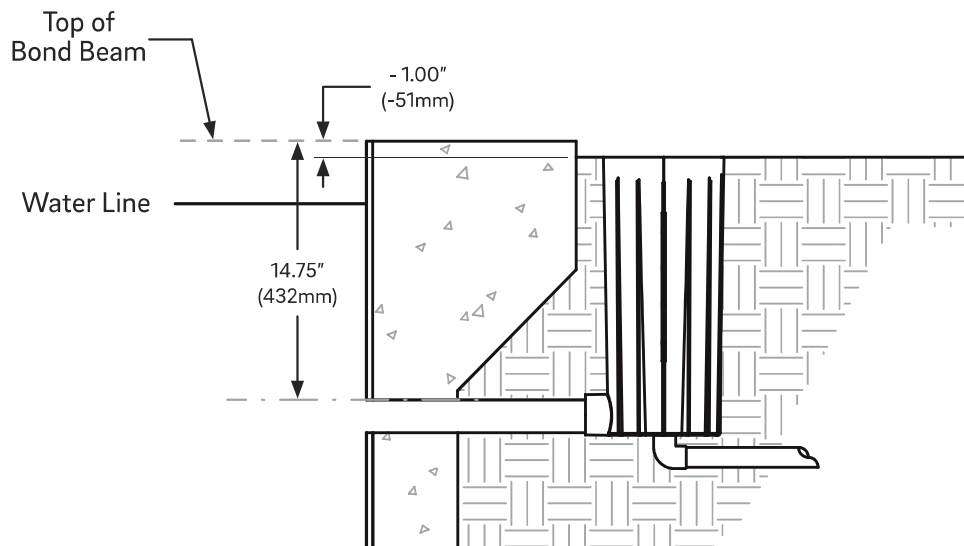

Figure 4

3. Once the desired height for the deck type listed above is identified, the glued connection for the feed line can be made. The lid and deck-ring can be adjusted and set by the deck personnel.

Plumbing the Discharge Line

Using 1.5" PVC, the discharge line can be installed by gluing an 18 inch length of pipe into the canister (Figure 5a) and then gluing a cap onto the other end. Be sure to allow enough pipe length so that the discharge line can extend into the pool at a 90° angle to the finished pool wall (Figure 5b).

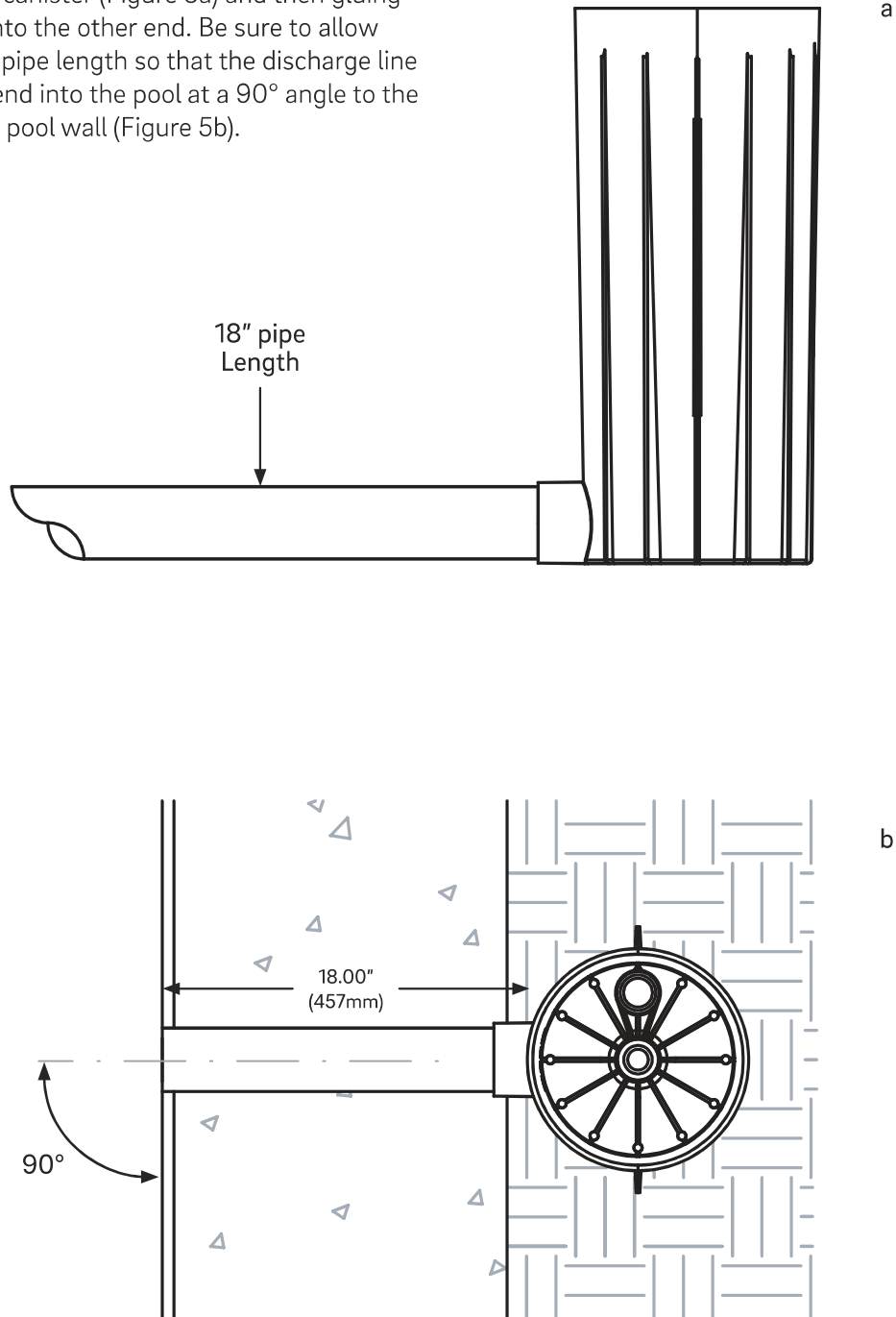

Figure 5

IMPORTANT

DO NOT drill out the port that is off-set from the center threaded hole inside the canister unless you are adding an overflow line to this water leveler.

NOTE:

The center threaded hole inside water leveler base has been pre-drilled. A disposable threaded plug has been factory installed into this port, making the unit ready for pressure testing. At start-up, merely remove this test plug with a large flat-head screwdriver and discard the plug.

Plumbing the Supply Line

1. Using 0.75" PVC, the feed line can be installed by gluing a 1.5 inch long piece of pipe into the center socket on the bottom of the canister and once that joint has set, dry-fit a 90° elbow.
2. From the 90° elbow, glue an 18 inch length of pipe and dry-fit a cap on the end to keep debris out of the line. Once the plumbing is complete, you may fill the canister and gravity test for leaks.
3. Now configure the supply line so that the pipe lines up with the pipe coming from the water source. Now glue the dry-fit 90° elbow in place (Figure 6).

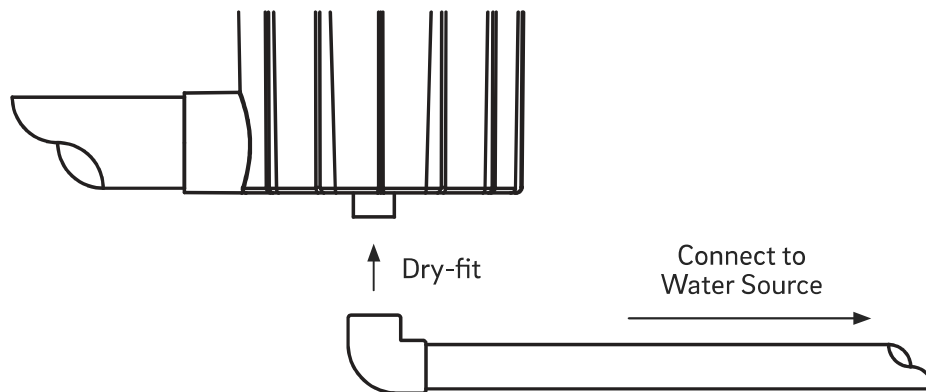

Figure 6

IMPORTANT

DO NOT glue the standpipe for the overflow line into the canister. This must only be dry-fitted into place to allow for future removal or replacement.

Plumbing the Overflow Line (optional)

1. Inside at the bottom of the canister, begin by drilling a 3/8" hole through the center of the protective membrane blocking the port that is off-set from the center threaded hole.
2. Cut a piece of 0.75" PVC pipe long enough to ensure that it will stand 1" above the pool water level and push it into the overflow fitting adapter.

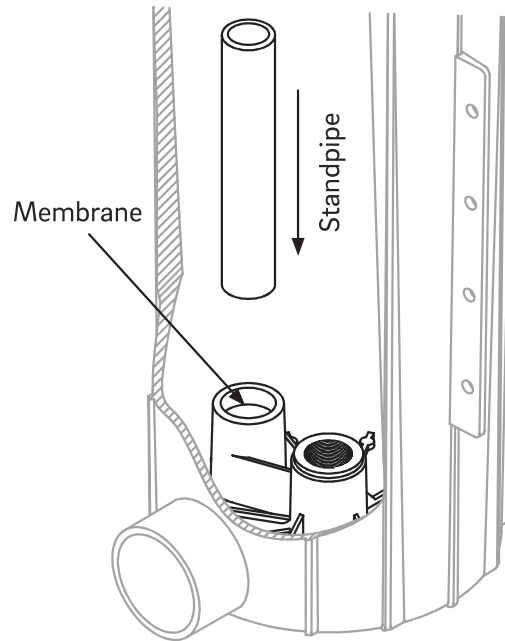

Figure 7

3. Using 1.0" PVC the overflow line can be installed by gluing a 2.25 inch long piece of pipe into the socket that is offset from the center on the bottom of the canister. Once that joint has set, dry-fit a 90° elbow.
4. From the 90° elbow, configure the overflow line so that it lines up with the pipe coming from the waste line or overflow pit. Now glue both sides of the dry-fit 90° elbow in place (Figure 8).

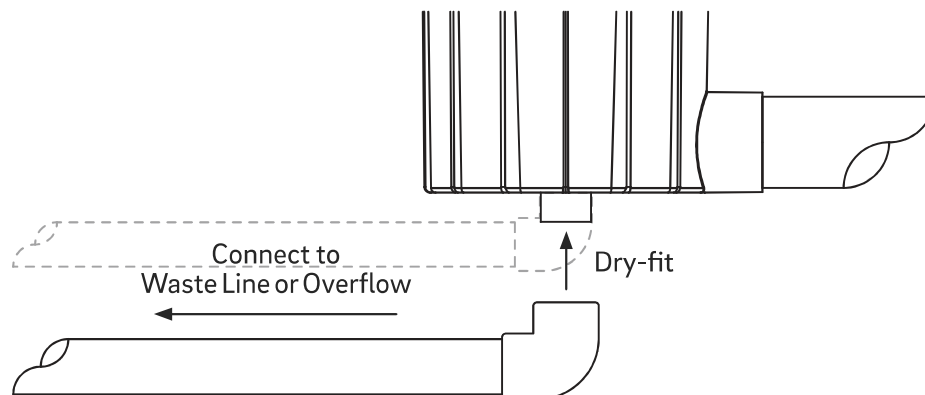

Figure 8

IMPORTANT

It is crucial that construction debris is purged from the line. Failure to do so may void the warranty.

DO NOT use Teflon sealant tape or compound on the float assembly or the canister. Either may damage the threads on the float assembly, the canister, or both. Failure to adhere to this guideline will void the warranty.

Startup Procedure

1. After the gravity leak test confirms that there are no leaks, clear any construction debris from supply line by allowing the full flow of water to into the canister for a minimum of 60 seconds. This must be done prior to installing the float assembly and failure to do so may void the warranty.
2. Before installing the float assembly, be sure to insert the white restrictor seal into the bottom of the center threaded port inside the canister (Figure 9). This must be done before threading in the float assembly. The restrictor seal reduces the flow entering the float assembly, while providing the necessary water-tight seal.
3. Once the float assembly is has been properly installed, it can be adjusted for the proper water height

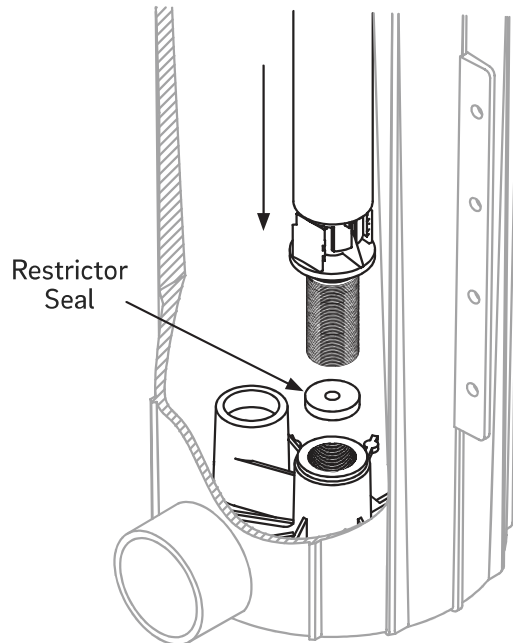

Figure 9

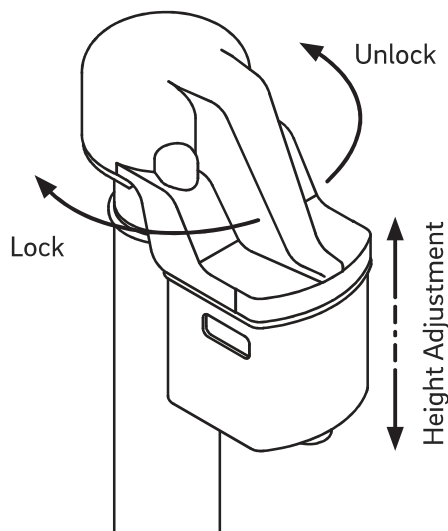

Figure 10

4. To make adjustments, unlock the float assembly by turning the upper float module counterclockwise and lift the module or push it down to achieve the desired water level. Once the desired level is achieved, lock the float assembly by turning the float module clockwise until it seats back in its original position.



Limited Warranty

To original purchasers of this equipment, A&A Manufacturing will warrant the QuikWaterLeveler from defects in materials and workmanship for a period of one year from the date of purchase.

The limited warranty excludes damage from freezing, negligence, improper installation, improper use or care or any Acts of God. Parts that fail or become defective during the warranty period shall be repaired or replaced, at A&A Manufacturing's option, within 90 days of the receipt of defective product, barring unforeseen delays, without charge. Proof of purchase is required for warranty service. In the event proof of purchase is not available, the manufacturing date of the product will be the sole determination of the purchase date. To obtain warranty service, please contact the place of purchase. A&A Manufacturing shall not be responsible for cartage, removal, repair or installation labor or any other such costs incurred in obtaining warranty replacements or repair.

The A&A Manufacturing warranty does not apply to components manufactured by others. For such products, the warranty established by the respective manufacturer will apply. The express limited warranty above constitutes the entire warranty of A&A Manufacturing with respect to its pool products and is in lieu of all other warranties expressed or implied, including warranties of merchantability or fitness for a particular purpose. In no event shall A&A Manufacturing be responsible for any consequential, special or incidental damages of any nature.

Please retain for your records.

Date of Installation _____



A&A Manufacturing

QuikWaterLeveler Warranty Registration Card

Directions: Please Fill out bottom portion completely and mail within 30 days of purchase or register your product online at www.amfg.com

Please Mail to:
ATTN: WARRANTY DEPT,
A&A Manufacturing
3750 W Indian School Dr, Phoenix AZ 85019

PLEASE PRINT CLEARLY

Owner Information

First Name _____ Last Name _____

Street Address _____

City _____ State _____ Zip _____

Phone Number _____ Purchase Date _____

E-Mail Address _____

Product Model Number _____

Original Purchase Information

Company Name _____

Address _____

City _____ State _____ Zip _____

Phone Number _____